

- Up to 60A / 250VAC Continuous rating
- Single coil & twin coil latching
- Utility meters
- Automotive / Electric vehicle battery

RoHS
Compliant ✓

Contacts

Contact arrangement	SPST-NO (1 NO)
Contact material	AgSnO ₂
Max. switching voltage	250VAC / 20VDC
Min. switching current / voltage	500mA/12VDC
Max. continuous current	60A
Max. switching current	60A
Max. switching power	60A: 15000VA / 1680W
Initial resistance	≤ 100mΩ, max. at 0.1A/6VDC

Coil

Rated voltage	9...48VDC
Operating range of supply voltage	See table 1
Rated power consumption	single coil 60A: 1.2W
Rated power consumption	twin coil 60A: 2.4W

Insulation (EN 60664-1)

Insulation resistance	>1000MΩ at 500VDC, 50%RH
Dielectric strength	coil to contact 4000Vrms, 1min (50Hz)
	between open contacts 1500Vrms, 1min (50Hz)
Creepage & Clearance	8mm

General Data

Operating time	max.	20ms
Release time	max.	20ms
Electrical life (resistive)	ops.	1 x 10 ⁴
Mechanical life	ops.	1 x 10 ⁶

Environmental

Ambient temperature	operating	-40 to 70°C (Class F)
	storage	-40 to 70°C
Humidity		98%RH, 40°C
Shock resistance	functional	100m/s ² 11ms
	destructive	1000m/s ²
Vibration resistance		DA 1.5mm 10-55Hz
Dimensions	L x W x H	38.6 x 33 x 17mm
Weight	approx.	≤ 45g

Ordering Code

D G 7 7 A - 3 0 2 1 - 7 2 - T L 2 4 -

Series

Coil code:

See table 1

Contact rating

A: 60A

Contact material

30: AgSnO₂

Contact arrangement

21: SPST-NO (1NO)*

31: SPST-NC (1NC)*

* As delivered condition

Environmental protection

7: Covered, dust cover

Mounting & terminations*

1: PCB coil terminals + weld terminals for contacts

Straight power terminals

2: PCB coil terminals + weld terminals for contacts

Bent power terminals

* Terminals are highly customizable.
Please contact factory.

Options

Blank: Standard

P*** : Custom (***) = unique identifier

DC Coil Data
Table 1

Coil voltage code		Nominal voltage (VDC)	Coil resistance (Ω) $\pm 10\%$		Must operate voltage (VDC)	Recommended operate pulse length
Single coil	Twin coil*		Single coil (1.5W)	Twin coil* (3.0W)		
SL09	TL09	9	54	27.0 to 27.0	≥ 6.75	50ms
SL12	TL12	12	96	48.0 + 48.0	≥ 9	
SL24	TL24	24	384	192 + 192	≥ 18	
SL48	TL48	48	1536	768 + 768	≥ 36	

* NB: Latch & Reset coils must not be powered simultaneously.

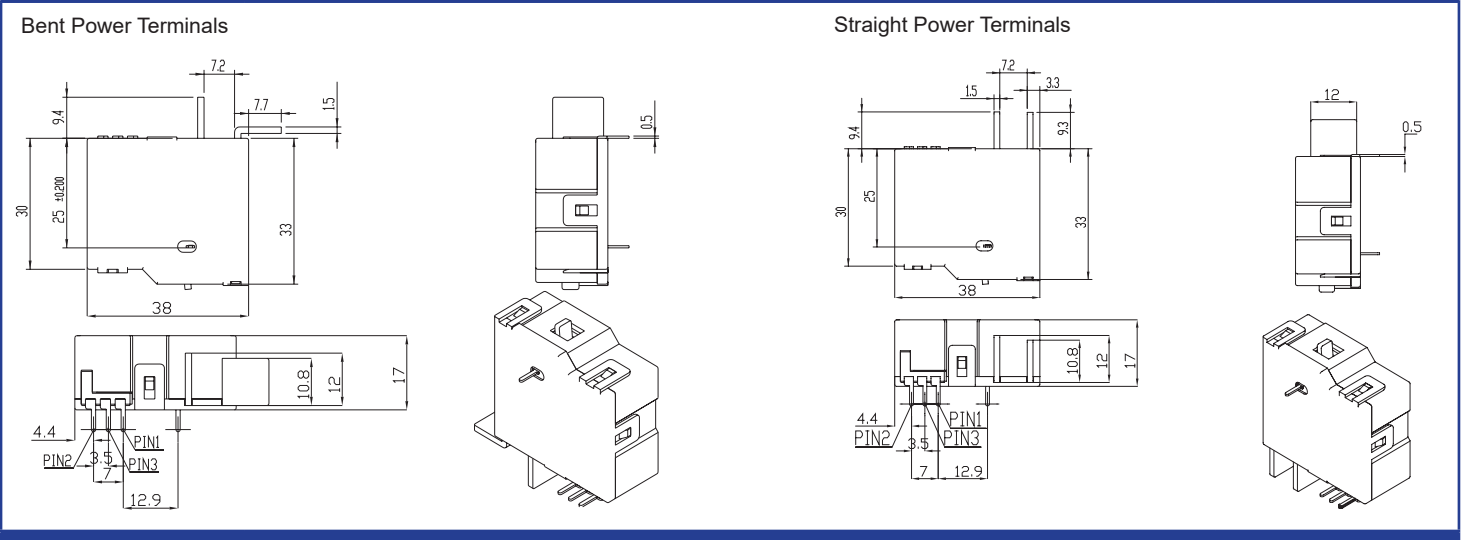
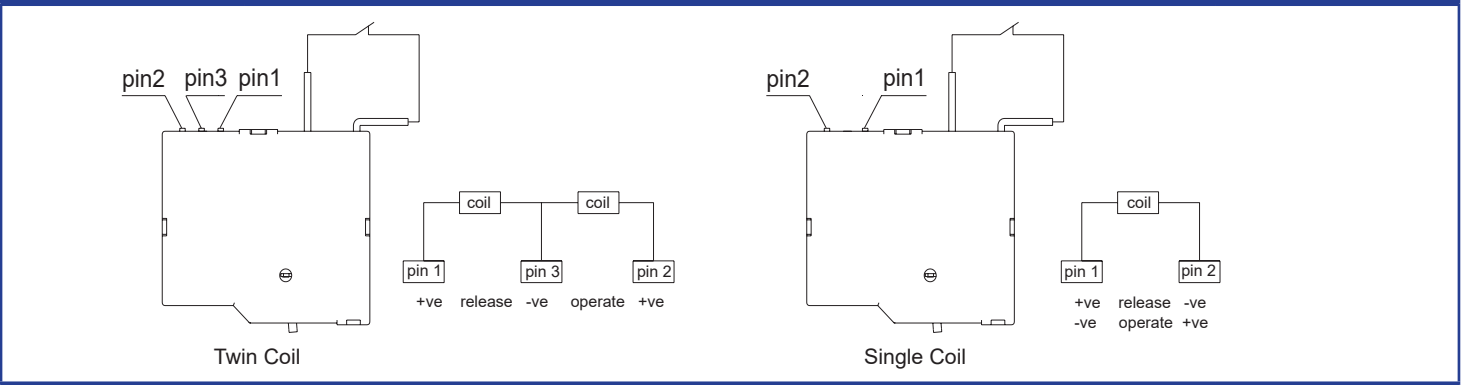
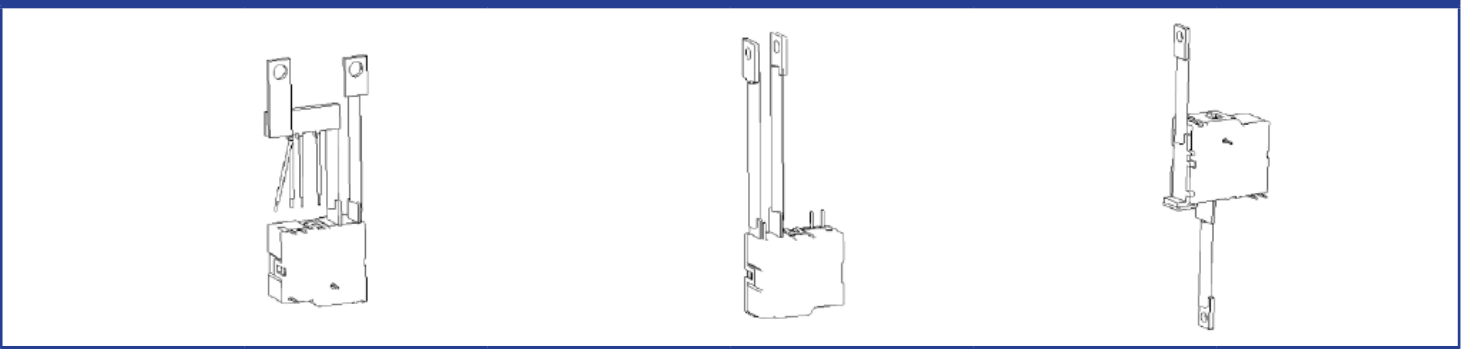
Overall Dimensions mm
Fig. 1

Wiring Diagrams
Fig. 2

Custom connection options: Illustrative examples with and without optional shunt
Fig. 3

Notes:

1) All parameters, unless otherwise specified, are measured at an ambient temperature of 23°C.