



- 500A Continuous
- Max. breaking current = 2000A
- Magnet arc blowout
- Auxiliary contact
- Male or female power terminals
- Side or bottom mount
- Available with PWM coil economiser



Contacts

Contact arrangement	SPST-NO-DM
Contact material	Oxygen Free Copper (Cu. C10200)
Max. switching voltage	DC 1000VDC (current dependent - see fig. 1)
Rated load (resistive, cos φ=1)	DC1 200A
Max continuous thermal current	DC1 500A with 300mm ² , or larger, conductors
	30s 600A
Instant peak current	max. 5000A / 10msec
Max switching current	1 time only 2000A @ 320VDC
Terminal temperature rise above ambient	<70°C. IEC EN60947 GB14/14048.4
Contact voltage drop	max. 80mV @ 200A
Auxiliary contact (when fitted)	arrangement SPST-NO (1 Form A)
	max. current 2A @ 24VDC / 3A @ 125VAC
	min. current 100mA @ 8V

Coil

Nominal voltage	DC 9 ~ 36VDC, 32 ~ 95VDC - see Tables 1 & 2
Rated power consumption	hold 2W approx.

Insulation

Insulation resistance	initial	>1000MΩ @1000VDC
	life end	50MΩ (Min.)
Dielectric strength	coil to contact	4000Vrms / <1mA / 1 min (at sea level)
	contact to contact	4000Vrms / <1mA / 1 min (at sea level)

General Data

Operating time at 20°C	max.	30ms
Release time at 20°C	max.	10ms
Bounce time at 20°C	max.	5ms
Electrical life	at rated load	10,000 operations @ 270VDC see page 2
Mechanical life		3 x 10 ⁵

Environmental

Ambient temperature	operating	-40 to +85°C
Relative humidity		20 to 90%RH
Shock resistance		100G peak, 11ms 1/2 sine, peak
Vibration resistance		20G sine peak (80 to 2000Hz)
Dimensions		see Figs. 4 & 5 (Page 3)
Weight	approx.	>450g (will vary according to option)

Ordering Code

D H V C 2 0 0 - 4 0 6 1 - S 8 - 0 9 3 6 - R 1

Series

Coil code:

See tables
1 & 2

Contact material

40: Cu. C10200

Contact arrangement

61: SPST-NO*

71: SPST-NO + Auxiliary*

81: SPST-NO

91: SPST-NO + Auxiliary

* Polarized - see Page 2

Mounting & terminations

Bottom mount

B8: M8 male stud power terminals

B9: M6 female power terminals

Side mount

S8: M8 male stud power terminals

S9: M6 female power terminals

Coil wire & auxiliary wire (when fitted) length

R: 390mm

T: 150mm

Coil wire & auxiliary contact termination

1: None (bare ends)

3: Mini-fit female (see Fig. 3)

▲ NB: UL ratings may differ and not all variants are UL approved. Contact Durakool for more information.

Coil Data (with PWM economiser) Table 1.

Coil code	Nominal voltage (V DC) U_s	Coil operating range (V DC)	Must operate voltage max. (V DC)	Must release voltage (V DC)	Starting current (A)	Maintain (hold) current (A)
0936	9 ~ 36	9 ~ 36	8 ~ 9	5.5 ~ 7.0	3.8	0.18 @ 12V 0.09 @ 24V
3295	32 ~ 95	32 ~ 95	31 ~ 32	18.0 ~ 20.0	1.4	0.03 @ 48V

PWM Coil economiser: no additional coil surge suppression required. Coil terminals are polarized. DHVC200 with coil code type 3295 is not UL approved.

Coil Data (no PWM economiser) Table 2.

Coil code	Nominal voltage (V DC) U_s	Coil operating range (V DC)	Must operate voltage (V DC)	Must release voltage (V DC)	Coil power (W)
1012	12	10.2 ~ 14.4	≤ 9.0	≥ 1.0	12 ~ 15
1024	24	20.4 ~ 28.8	≤ 18.0	≥ 2.0	12 ~ 15
1048	48	40.8 ~ 57.6	≤ 36.0	≥ 4.0	12 ~ 15

Only available with polarized power terminals - contact codes "61" & "71". DHVC200 types without economiser are not UL approved.

Electrical performance

Fig. 1.

Electrical life: Resistive load, polarized types only

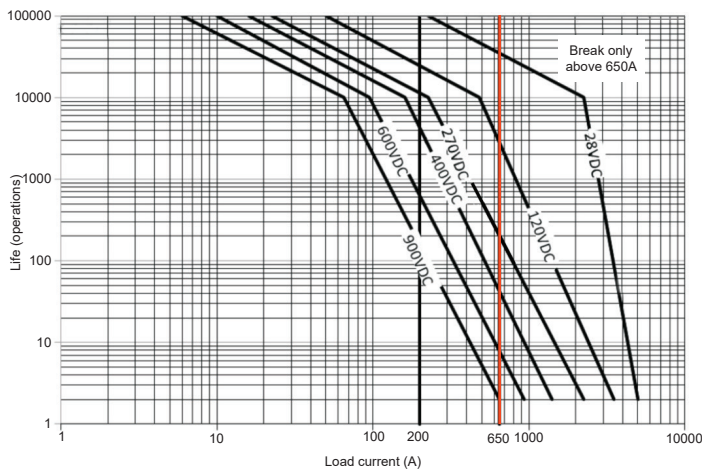

Electrical Life: Resistive load, non-polarized types only

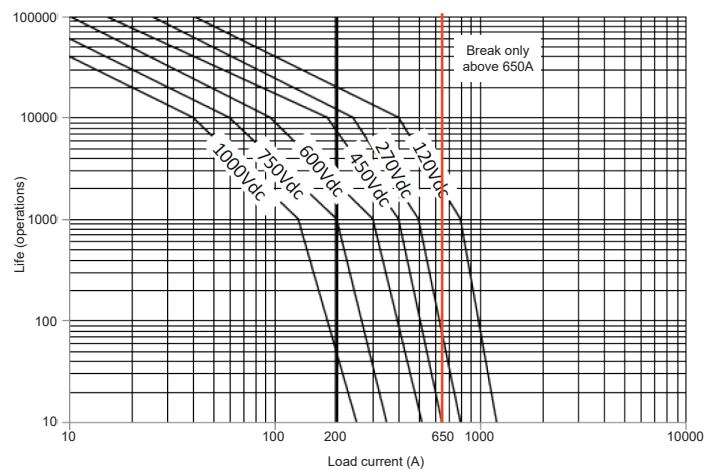

Carry current with 95mm² conductors (300mm² recommended for best performance): 200A Continuous, 300A 60m, 400A 20m, 800A 30s, 2000A 0.6s

Carry current is highly dependent upon conductor size.

Life estimates are based on tests and extrapolated data.

The user is advised to confirm the performance in their application.

Connection Diagram

Fig. 2.

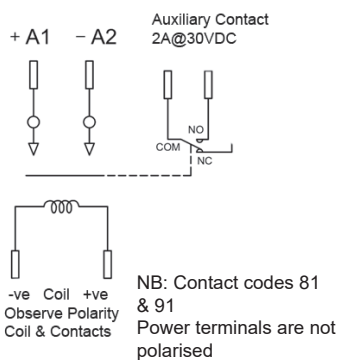

Optional Mini-fit Connector

Fig. 3.

Connector for coil and auxiliary contact (2 x)

- 1 = Coil lead +ve terminal (red)
- 2 = Coil lead -ve terminal (black)

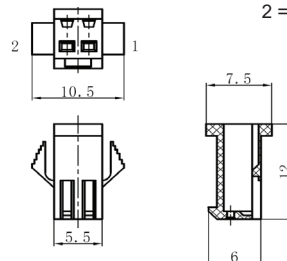

Fitted socket type = SM-2A-HW
Fitted terminal type = SMY-HW

Dimensions - PWM type (with economiser)

Fig. 4

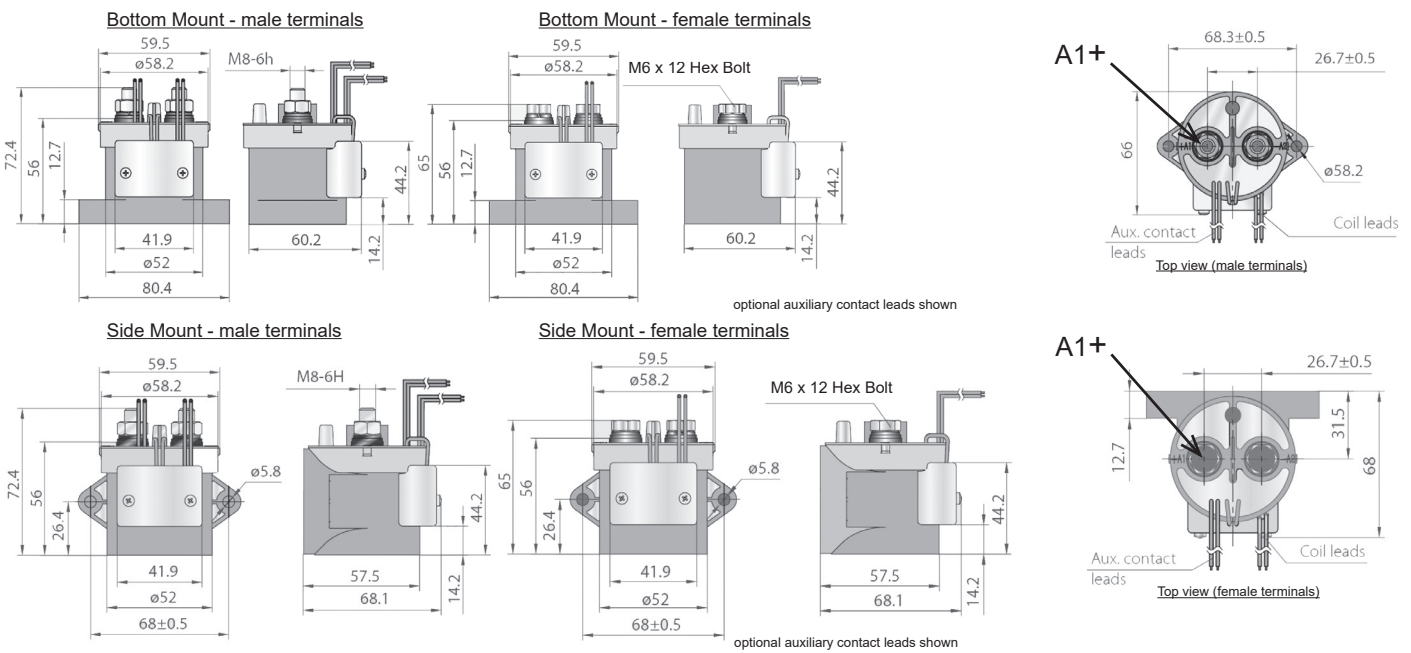

Dimensions - No PWM type (no economiser)

Fig. 5

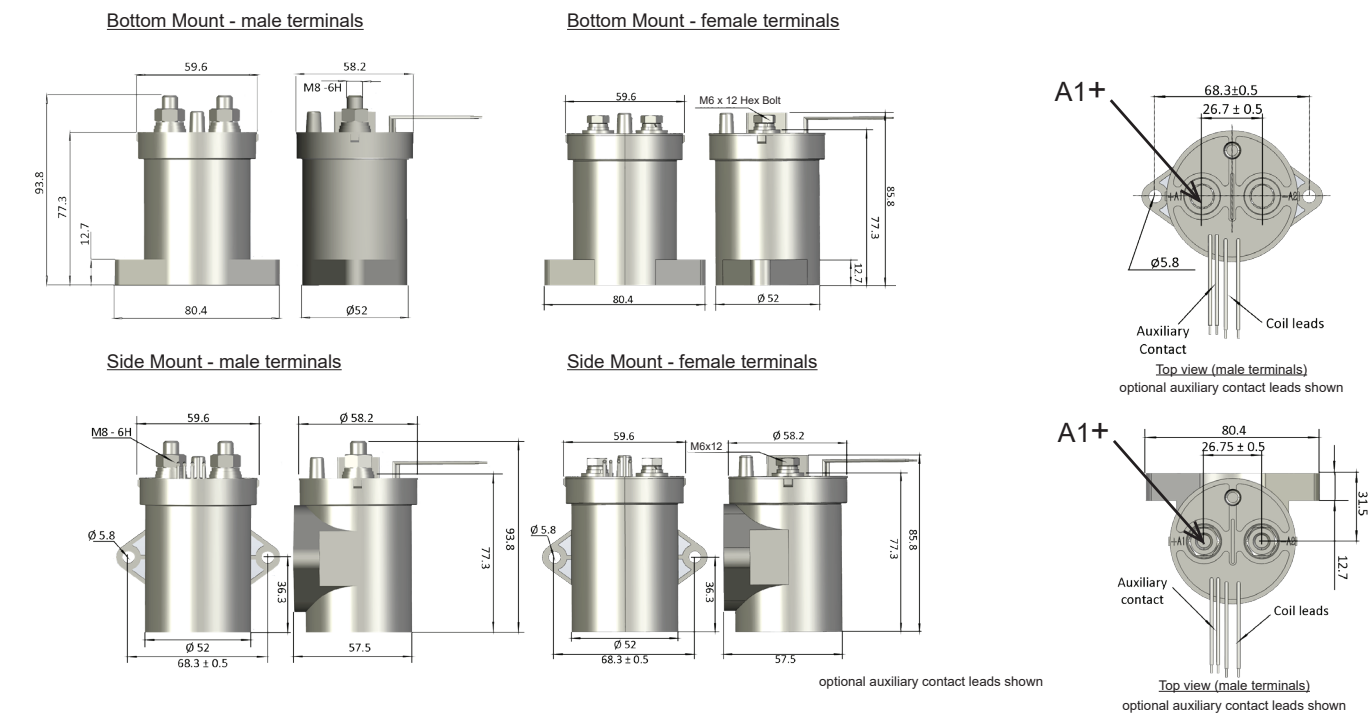

Notes:

- 1: Polarity sensitive types 61 & 71: Observe contact polarity as indicated. Contactor life will be severely reduced if incorrectly connected.
- 2: The maximum make current is 650A to avoid contact welding.
- 3: Nominal dimensions in mm. Tolerances (nominal), <10mm: ± 0.3mm, 10 ~ 50mm: ± 0.6mm, >50mm: ± 1.0mm.
- 4: Power contact (M8) nut torque = 8 ~ 10Nm, Power Contact (M6) nut torque = 6 ~ 8Nm; Installation/mounting torque = 1.7 ~ 3.5Nm.
- 5: Coil wire length and terminations can be customised upon request.
- 6: Coil and auxiliary contact wires: Teflon insulated UL1887 20AWG
- 7: Main contacts should be connected with cable section of more than 250mm², if used at maximum rated current.